

The Influence of Communication Channels on Management Practices in Kenyan Public Universities

Mamuli, L.C.

Email: butali2003@yahoo.com

Mutsotso, S.N.

Email: smutsotso@kibabiiuniversity.ac.ke

Namasaka, D.B.

Email: butnams@yahoo.com

Abstract

This study was conducted at Masinde Muliro University of Science and Technology. It was guided by communication model as propounded by Shanon and Weaver (1949). This study was designed to investigate the influence of communication channels on management practices in Kenyan public universities. The study specifically investigated the types of communication channels used in the university and related the channels to the constraints faced in communicating messages in the university. Literature was reviewed in relation to the above stated objective. The study sample was drawn from MMUST and involved both academic and administrative staff. The sample size was one hundred and fifty two (152) which represents 77.6% of the target population. Stratified random sampling techniques based on the respondents' job descriptions were used. The instruments for data collection involved use of questionnaires and information from secondary data materials for instance the University Act of 2007 and the employee survey findings of 2006. Data was analyzed using descriptive statistics. The major findings revealed that MMUST had few channels of communication and that the communication policy framework was in place. However, the study identified that MMUST relies on Head of Departments, Group representatives, memos, notice boards, face to face and telephone to communicate. The study therefore, recommended that MMUST embraces new channels of communication (i.e. use of email) for efficiency purposes in addition to the already existing ones. Also, the university should adopt strategies of enhancing communication between the staff and administration.

Keywords: Organization, Communication, Influence, Teaching, Research, Channel

Introduction

The ultimate aim of every organization is to accomplish its set goals. But more often than not, the attainment of this noble target is always ensured or jeopardized by the communication network put in place by the management. Communication is a central activity to human

existence. It bears on every sphere of human endeavor. It is the medium through which relationships are established, extended, maintained and sustained. It informs all human actions because it is occasioned by the need to interact with fellow humans. An organization on the other hand, is a social system composed of interdependent groups (of people) attempting to achieve commonly recognized goals. All activities in the organization revolve around human beings, within the context of an organization. Organizational communication, then, involves understanding how the context of organization influences communication processes and how the symbolic nature of communication differentiates it from other forms of organizational behaviours (Miller, et.al. 1994). Through communication, new entrants are introduced to their jobs and work environment. Properly used communication helps to get such new employees integrated into their new work environment and networks of interpersonal relationships of peer employees, supervisors and subordinates (Soola, 1998). In short, communication stands the place of pride as a unifying bond in a bid to accomplish organizational goals.

Anyakoha, et.al. (1995) emphasized that Universities are successful primarily because of their teaching and research, not because of their management, but good management can, over time, provide the conditions in which teaching and research can flourish, just as, more usually, poor management can undermine teaching and research and ultimately precipitate institutional decline. However, one essential characteristic of successful universities is the speed of communication that is necessary between different organs of the university. Good academic performance is made up not of a series of isolated processes but of a closely interrelated network of activities which combine to produce an effective academic product. Shattock (2003), asserted that in an inter-university competitive environment, how a single staff vacancy is filled or whether a particular allocation of equipment grant is made can have strategic importance for a department and, therefore, on the department's, and on the university's longer term performance.

The organizational structure of MMUST is based on the University Act of 30th December, 2006. The University is run by the University Council as the supreme organ with the day to-day activities run by Senate, chaired by the Vice Chancellor. The Senate comprises of the Vice Chancellor, Deputy Vice Chancellors, Deans of Faculties, Directors of Institutes, Schools and Centres, Chairpersons of Teaching Departments, the University Librarian, representatives of Librarians, faculty representatives, professors, student representatives, trade union representatives and Coordinators of Campuses and other directorates. At all levels of administration and management, there is usually upward, downward horizontal and lateral communication. There are issues of concern that require managers and administrators to consult over and make decisions that guide provision of services as promised in the service charter. The coordination of administrative, financial, academic functions of the University is placed in the offices of the Deputy Vice Chancellors supported by professional experts. It was in view of the above that the study was done to investigate the types of communication channels and their influence on management practices at MMUST.

The study integrated three theoretical perspectives of communication and one theoretical perspective of organizational management. The technical, contextual, and the negotiated perspectives of communication and the critical approach of organizational management were used. The technical view of communication is associated with information theory and is traced back to Shannon and Weaver (1949). Shannon, portrayed communication as a mechanistic system. The mechanistic system considers how an information source gets a message to a destination with minimal distortions and errors. The technical view of communication is relevant in this study since the communication process consists of the message, sender, channel, receiver and feedback. In this case, the message should be encoded correctly and an appropriate channel of communication chosen for the message to reach the recipient with minimal distortions thus preventing barriers to communication. The mechanistic system is shown in Figure 1 below:

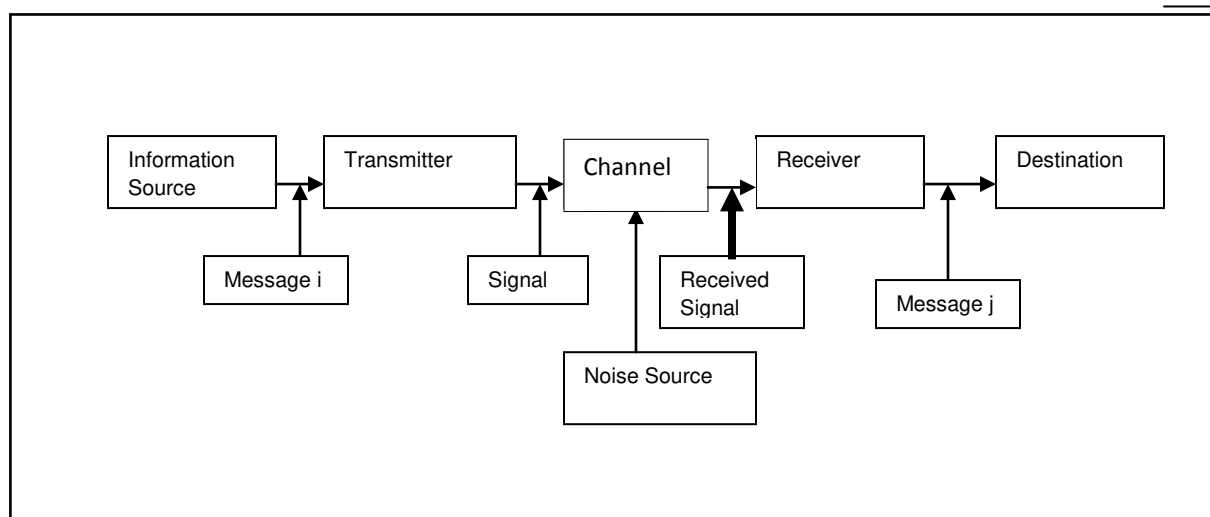

Figure 1: Communication as a mechanistic system

Adopted from Shannon and Weaver (1949)

According to Shannon and Weaver's model in Figure 1 above, a message begins at an information source, which is relayed through a transmitter, and then sent via a signal towards the receiver. But before it reaches the receiver, the message must go through noise (sources of interference). Finally, the receiver must convey the message to its destination. Shannon and Weaver's (1949) model clearly demonstrates why even the simplest communication can be misunderstood. Transmitting a signal across additional media only adds to the complexity of the communication and increases the chances for distortion. It is suddenly easier to understand why other people cannot comprehend what is already in the public domain. In this study therefore, the mechanistic approach is relevant since it depicts how information moves from the source to the recipient and back to the source. The approach ascertains that communication can occur with minimum distraction and therefore can be responded to appropriately.

Communication being a day to day activity is a process incomplete without a channel. The channel is a vital link in communication and it is important to know the channels to make communication effective. Payne (2001) defined channels as the means used to transmit the message from sender to receiver. Just as television programmes broadcast over many channels, messages can be transmitted through many channels. The choice of channel depended on time available, expenditure involved, urgency of the information and intellectual and emotional state of the sender and receiver.

Bizmove.com (2002), in their article on 'Communicating within an organization' explained that the communication channel selected for transmitting a message plays a significant role in maintaining the quality of the original message in its passage from the sender to receiver. The sender, given the opportunity to weigh the merits of using an oral or written communication, or a combination of the two, selects the most effective for the situation. The following are the channels of communication that an organization can have; Formal communication which refers to communication within the formal organizational structure that transmits goals, policies, procedures, and directions, Informal communication which refers to the communication outside the formal organizational structure that fills the organizational gaps, maintains the linkages, and handles the one-time situations and unofficial communication which refers to the interpersonal communication within (or among) the social structure of the organization that serves as the vehicle for casual interpersonal exchanges, and transmittal of unofficial communications.

Bizmove.com (2002), in their article on 'Communicating within an organization' further reiterated that in the development of an organizational structure, communication channels are an important consideration. The manager in a hierarchical system becomes a link in the communication chain. It is the hierarchical system that gives direction to and imposes restrictions upon the flow of communications. Management decisions and directions flow from higher to lower levels in the organization. Responses and reports from the lower level managers flow upward in the organization. Managers also spend time communicating with their peers. Therefore, we see from the outset that communications must function effectively in a lateral direction, as well as downward and upward.

Committees in the universities on the other hand, influence the communication process within a university. A well-run committee can serve as a supplementary link in the communication chain and provide a means for disseminating information. However, committees often fail to ensure that the Dean of Faculty A and the Dean of Faculty B tell each other what they wish or need to know. Although they cannot give directions or issue procedures, staff members influence the communication process within a university. The advice or recommendations of staff members are accepted by subordinate staff, because of the anticipated support by the staff member's superior. When a staff member is given functional decision prerogatives, he/she essentially assumes the same status as his/her superior with respect to such matters. T. C. Warner believes that "one's accomplishment is... in a very real sense dependent upon the quality of the communication with others." O'Connor, (1997) reiterated that, there was no

more valuable asset in business life than the ability to express one's thoughts with clarity and precision.

Sillars (1999), further stated that there were several channels of communication; there are written, verbal, oral, visual, audio-visual, electronic, special needs, grapevine and jungle just to mention a few. That oral communication was communication by word of mouth and it may be direct, when two people meet and talk or remote, when the telephone is used. The examples of oral communication included; unplanned exchange, planned formal talk, interview, telephone call, group meeting, committee meeting, full staff or employees' meeting and formal presentation. Forms of written communication include informal note, memo, letter, circular letter, press release, forms, notices, reports, and electronic means among others. He further listed examples of visual communication as, moving images, graphic communication, photographs, pictures and drawings.

Andrews and Herschel (1998) further reiterated that as population grows and technology evolves, there was need for efficient channels of communication for effective communication as the world has now become a global village. Due to technology explosion; multiple new channels of communication had come up and were a threat to the channels that have been used over years. For example, fewer people used the written modes of communication currently compared to the past years. People currently preferred use of phone calls or use of emails. In organizational settings, information flows formally and informally. The conventionally most favored system of communication is the formal (downward) communication system which normally takes the forms of memos, reports, staff-meetings, departmental meetings, conferences, company newsletter, official notices and so on Mishra, (2005). Therefore, communicators need to consider the situation, purpose and audience before deciding the channel most suitable.

According to Koontz, O'Donnel and Weirrich (1980) downward communication (alone) does not work (in an organization) because it ignores the receiver of the communication. Adegbite (2000) corroborates the view above in the following words "anything short of mutually open communication system (in an organization) heightens tension. It makes nefarious and broadens the spectrum of informal channel (rumor and the grapevine)". Informal communication structure, according to Rogers and Rogers (1976) cited in James, Ode and Soola (1990), is "determined by proximity and mutual attractiveness of individuals who interact in work places and in other activities. In the same way, it is also determined by similarities of values and social characteristics". Rumor could be peddled about an organization by the members of the organization or by outsiders. But the grapevine is essentially a channel through which stories about an organization is spread within the organization and by the members of the organization. Information carried by grapevine is always related to some aspects of the life of the organization; for instance, policies, personnel transfers, promotions or resignations. MMUST has both the formal and informal communication channels.

Methodology

The study was conducted at Masinde Muliro University of Science and Technology and was guided by descriptive survey design. MMUST had twenty six (26) departments at the time of the study. The 26 departments were divided into two major strata, that is, twenty one (21) teaching and five (5) non teaching departments. Out of these ten (10) departments representing 37% of the population was selected using random stratified sampling to participate in the study.

The strata were further subdivided based on members sharing a specific attribute or characteristic for instance lecturers, administrators, secretaries, technicians among other cadres of staff. A simple random sample from each stratum was taken, in a number proportional to the stratum's size when compared to the population. These subsets of the strata were then pooled to form a random sample. The subjects from the selected population were selected to ensure that they were a representative of the population in terms of such critical factors as sex, faculties, years of experience and rank. To arrive at sample size of 152 individuals, the researcher adopted a sample determination table used in social research. (Saunders, et al, 2009:212). The ideal was 196 but because the response rate was not 100%; the researcher contended with this sample which represents 77.6%.

Sixty (60) lecturers, forty (40) administrators, eleven (11) secretaries, five (5) accountants, ten (10) technicians, twenty (20) office assistants and six (6) other staff were purposively sampled and participated in the study. A total of one hundred and fifty two (152) members of staff were sampled for the study as shown in Table 1 below;

Table 1: Sample Size

Category	Population Permanent Pensionable Terms	on & Sample	Percentage (%)	Sampling Technique
Lecturers	180	60	33.3	Random
Administrators	120	40	33.3	Random
Secretaries	33	11	33.3	Random
Accountants	16	5	31.2	Random
Technicians	30	10	33.3	Random
Office Assistants	60	20	33.3	Random
Others (Clerks and Cleaners)	21	6	28.5	Random
Total	460	152	33.0	

The study used questionnaires, interview schedules and observation guide to collect data. The instruments used consisted of both open and closed ended questions that captured the respondents' personal background, channels of communication used in MMUST, influence of communication on management practices and communication barriers experienced.

Results and Discussion

Types of Channels of Communication in the University

The respondents were asked to rank the types of channels of communication in existence at Masinde Muliro University of Science and Technology and the results are shown in Table 2 below;

Table 2: Types of Channels of Communication in MMUST

Gender of Respondent	Channel of Communication	Ranking			
		1	2	3	4
Male	Group Representatives	41.2%	35.3%	11.8%	11.8%
	Head of Department	85.7%	14.3%		
	Suggestion Box			33.3%	66.7%
	Individual	7.7%	23.1%	46.2%	23.1%
Female	Group Representatives	23.5%	47.1%	29.4%	
	Head of Department	67.7%	25.8%	6.5%	
	Suggestion Box			7.1%	92.9%
	Individual	18.8%	25.0%	43.8%	12.5%

The results in Table 2 shows the types of communication channels in existence at MMUST in terms of preference of the channels of communication as per the gender of the respondents. The male respondents ranked use of Heads of Departments first at 85.7% meaning that it is their preferred channel of communication. They also preferred use of the Group Representatives in which 41.2% of the male respondents ranked it first. Use of individuals as their channel of communication was not preferred since only 7.7% of male respondents ranked it first. The results further showed that male respondents did not use Suggestion Box as a channel of communication since none of them ranked it first and second instead it was ranked third and fourth. Results for female respondents showed that they also preferred use of Head of Departments as a channel of communication. 67.7% of the female respondents ranked it first. The female respondents also ranked use of Group representative first at 23.5% and use of Individuals at 18.8%. Use of Suggestion Box was ranked third and fourth meaning that it was not their preferred channel of communication. It was therefore deduced that channels of communication exist at MMUST and that both male and female respondents preferred use of

the Head of Departments and Group Representatives as their channels of communication while use of individuals and Suggestion Box were rarely used.

From the results presented, both male and female respondents preferred communication through their heads of departments. This is an indication that they prefer top to bottom communication. In Masinde Muliro University of Science and Technology, it is Heads of Departments who attend most decision making meetings then pass on the resolutions to other members of their departments for implementation. As agents of the University administration and management, the HoD's are the ones through whom official communication is passed on to the other members of the departments. It is this official responsibility bestowed upon them that necessitates their active participation in the dissemination of all official communication.

Both male and female respondents ranked group representatives as second most preferred channel of communication. This could be because of the organizational structure of the university. At the departmental level, the Chairmen and Heads of Departments appoint some members to be in charge of groups for efficient monitoring and supervision of performance of duties. This in turn enables the Heads of Departments to make sure that official channels of communication are followed. This is line with Dull (1981) who observed that in an organization, staff spent a large proportion of time talking to colleagues, dictating letters, participating in meetings, consulting with stakeholders, preparing reports etc.

The results also indicate that respondents did not prefer communication from individuals as it was ranked third. This could be attributed to the fact that communication from individuals may not be taken seriously by other colleagues as it may lack authority and authenticity. This medium of communication brings about distortion of information as no one may be held accountable for any mishap that may occur. Communication from individuals is usually taken as hearsay and therefore does not elicit desirable response from staff who are supposed to take action.

Both male and female respondents ranked communication through suggestion boxes fourth. This indicates that this is the least preferred channel of communication. This could be attributed to uncertainty about whether the target recipient of the information has received it or not. Communication through suggestion boxes is an informal channel of communication where feedback is not guaranteed. In an institution of higher learning, most of the communication that is circulated is official and there must be effective and efficient method of passing information from the managers to the implementers to elicit desired response from both sides. This observation concurs with Osborn (1997) who observed that the capacity of a channel to carry out information effectively lend insight to how various channel alternatives may be used depending on the type of message to be conveyed. He further stated that the richest channel was face to face.

Conclusion

From the study, it is concluded that Masinde Muliro University of Science and Technology relies mostly on Heads of Departments, group representatives, memos, notice boards, and the telephone as channels of communication. However, there are many other channels that MMUST can use so as to achieve effective communication. For instance electronic mail and teleconferencing. From this it is evident that communication channels influence management practices. This was attributed to the fact that any failure of information reaching its targeted staff has always had an impact on the management practices which include planning, organizing, leading and controlling and coordinating activities within the university. This is because the delayed or distorted information would misdirect the staff thus resulting in confusion. Most respondents concurred that communication channels influenced management practices in the university.

References

- Altinoz, M. (2008), "An Overall Approach to the Communication of Organizations in Conventional and Virtual Offices." Proceedings of World Academy of Science, Engineering and Technology.31,475 – 481.
- Andrews, P.H. and Herschel, R.T., (1998), *Organizational Communication, Empowerment in a Technological Society*. Houghton Mifflin Company.
- Anyakoha, E.U.; Uzuegbunam, A. and Ezeike, K.S. (1995), "Channels of Communication between Students and Administration in Nigeria Universities: Obstacles, Enhancement Strategies and Implications for University Governance." Research Report, Social Science Council of Nigeria/Ford Foundation National Research Programme on University Governance in Nigeria.
- BizMove.Com.(2002),"Communicating Within the Organizations," BizMove.com – The Small Business Knowledge Base,URL<http://www.bizmove.com/skills/m8m.htm>.Last accessed 4 November 2002
- Carriere, J. and Bourque, C. (2008), "The effects of organizational communication on job satisfaction and organizational commitment in a land ambulance service and the mediating role of communication satisfaction." *Career Development International*, 14 (1), p. 29 – 49.
- Daily Nation (2009, March 18),"Varsity Students on the Rampage." Nairobi: Nation Media Group.
- Downs, C.W. and Adrian, A.D. (2004), *Assessing organizational communication: strategic communication audit*. New York: The Guildford Press.
- Downs C.W. and Hazen M.D. (1967).,"A Factor Analytic Study of Communication

Satisfaction.” *Journal of Business Communication* 14: 63-73.

Euster, J. (1981),”Changing Patterns in internal Communication in Large Academic Libraries.” Occasional Paper Number 6.

Fiske, J.,(1990),*Introduction to Communication Studies*.2nd Edition, Guernsey Press Co.Ltd,Great Britain.

Gibbs, J. (1961) ‘Defensive Communication’ (2008) in David Mortensen, C. (ed.) *Communication Theory*. 2nd Revised edition. New Jersey:Transaction Publishers, p.44

Goldhaber, G.M. (1983), *Organizational Communication*. 6th ed. Dubuque, IA: Brown and Benchmark

Goodman, M.B.(1995),*Corporate Communication: Theory and Practice*. Albany. State University of New York Press.

Goodman, M.B.(1998),*Corporate Communications for Executives*. Albany. State University of New York Press.

Manning, P.K.(1992),*Organizational Communication*. New York: Aldine de Gruyter.

MMUST, (2004), Strategic Plan 2004-2010: Masinde Muliro University of Science and Technology. Kakamega: MMUST

McNamara, C.(2008),*Basics in Internal Organizational Communication*. Free Management Library. Authenticity Consulting, LLC.

Mugenda, O.M. and Mugenda, G.A. (1999), *Research Methods*. Nairobi: African Centre for Technology Studies.

National Universities Commission (NUC) (1996), *Draft Manual on University Management*. Nigeria, NUC.

Okafor, N., (1992),”The Academic Administration.” In Eze, F.C. and Ejiofor, P.N.(1992)(eds).*Towards Efficiency in University Administration*. Nigeria. Summer Education Publishers Limited.

Petit, J.D., Goris, J.R. and Vaught, B.C.(1997),”*An Examination of Organizational Communication as a Moderator of the Relationship Between Job Performance and Job Satisfaction*”.*Journal of Business Communication*, 34(1), 81-89(EJ 553 694).

Pincus, J.D. (1986), "Communication satisfaction, job satisfaction, and job performance." *Human Communication Research*, 12 (3), p. 395 – 419.

Shannon, C.E. and Weaver, W. (1949), *The Mathematical Theory of Communication*. University of Illinois Press, Champaign, IL.